

THICKNESS: 0.8~1.5t

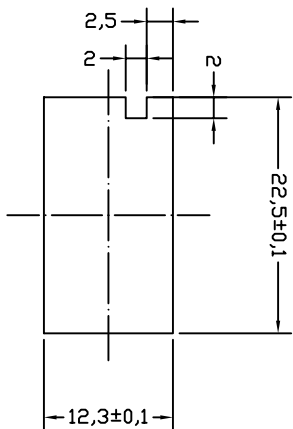

PANEL  
CUT-OUT

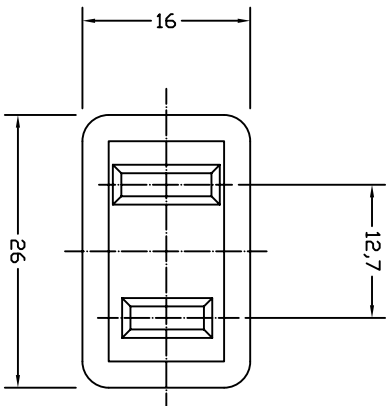
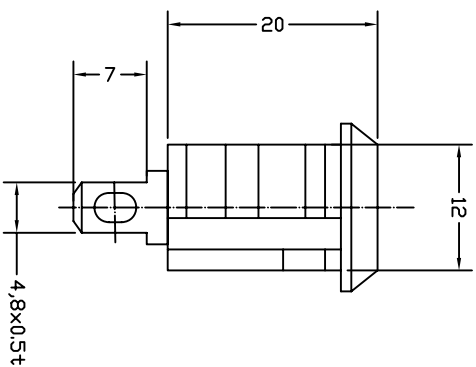
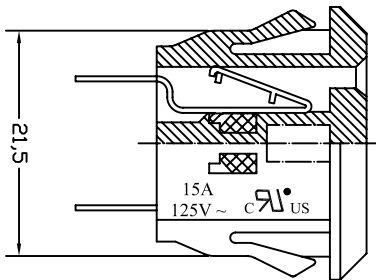

- A: MATERIAL: NYLON 66 FLAMMABILITY UL 94V-2  
 1. HOUSING: NYLON 66 FLAMMABILITY UL 94V-2  
 2. TERMINAL: COPPER ALLOY

- B: CHARACTERISTICS:  
 1. RATING: 15A 125V AC  
 2. INSULATION RESISTANCE: OVER 100MΩ AT 500V DC  
 3. DIELECTRIC STRENGTH :2000V AC ONE MINUTE

- C: APPROVALS:  
 UL, CSA,  
 D: ORDERING OPTION GUIDE

ORDER#	ITEM REQ.	TERMINAL DIFFERENCE
2115-PQ-G	1+2	4.8 SOLDER/Q.D TABS

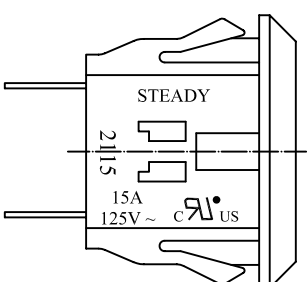

ITEM	PART NO.	PART NAME	QTY	SPECIFICATION	MATERIAL	REMARKS
2	T-15Q	TERMINAL	2 PCS	Ø4.8x±0.5t	COPPER ALLOY	TIN-PLATED
1	H-15P-G	HOUSING	3.5g	SNAP-IN TYPE	PA66	HERMETIC

深圳市仁达电子有限公司  
 SHEN ZHEN STEADY ELECTRONICS CORPORATION

TOLERANCE UNLESS OTHERWISE MARKED  
 DIMENSION: ANGULAR ±0.5

0~6 : ±0.1  
 6~30 : ±0.2  
 30~120 : ±0.3

UNIT:	SCALE	SHEET
mm	1:1	1 OF 1

MATERIAL: SEE ABOVE  
 SPEC.:  
 APPROVED: \_\_\_\_\_ CHECKED: \_\_\_\_\_ DRAW BY: 侯锡强  
 JOB NO.:

REV	DATE	DESCRIPTION	WRITE	APPD.
A.0	2008.02.25	RE DRAWING	侯锡强	
4				

